



REVOLUTION

Freshness Revolutionized

LOWER VOLUME

20  MIN.

Squeeze the most out of your space and oranges: Modern efficient design and high performance on 9" of counterspace.

FOCUSED DESIGN:

- Self-service and staff-operation for the smallest spaces.
- Ideal for locations serving orange juice by the glass.
- Simply press the tap or button to start juicing.
- Long fruit supply tunnel holds up to 6 oranges.

USER-FRIENDLY EFFICIENCY AND HYGIENE:

- One single Cross Holder secures all juicing elements.
- Fast and easy disassembly, cleaning, and reassembly.
- Double Cover separates juice zone from motor and keeps juicer housing clean.
- Dishwasher-safe juicing parts for improved hygiene.

SUPERIOR TASTE: SCS knife delivers precise fruit cuts, reduces peel oil, and yields sweeter-tasting juice.

SMART TECHNOLOGY: Multi-functional digital display with fruit counter, intelligent stop, and more.

PROVEN QUALITY: 100% Citrocasa quality in compact design. Our slimmest juicer for lower volume yet high performance.



REVOLUTION



LOWER VOLUME CITRUS JUICER

Fruit per minute	Net weight
20 pieces	97 lb
Fruit supply tunnel	Power Supply
6 pieces	120 V / 60 Hz
Fruit supply basket (opt.)	Power
20 lb	200 W / 0.2 kW
Fruit type	Fuse / Protection
Citrus fruit (oranges)	6.3 A / IPx1
Fruit size, Standard Pressing Kit (incl.)	Warranty
2.55-3.14 in	Limited 2-year
Juicing modes	Certifications
Self-service tap / Continuous	NSF, TÜV America, ISEGA, ANSI and SCC accredited
Installation	Parts and Support
Free-standing / countertop kit / Stainless-steel cabinet	(407) 790 7862 www.citrusamerica.com

OPTIONAL ACCESSORIES:

- | Fruit Supply Basket
- | Counter-Installation Kit with large 130-fruit-capacity waste bucket
- | Rolling Stainless-Steel Cabinet
- | Bottle Dispenser | Slide Tray
- | Display Shelf



2-ZONE-TECHNOLOGY:

Complete separation of *motor zone* and *juicing zone* with stainless-steel Double Cover for improved hygiene and cleaning efficiency.

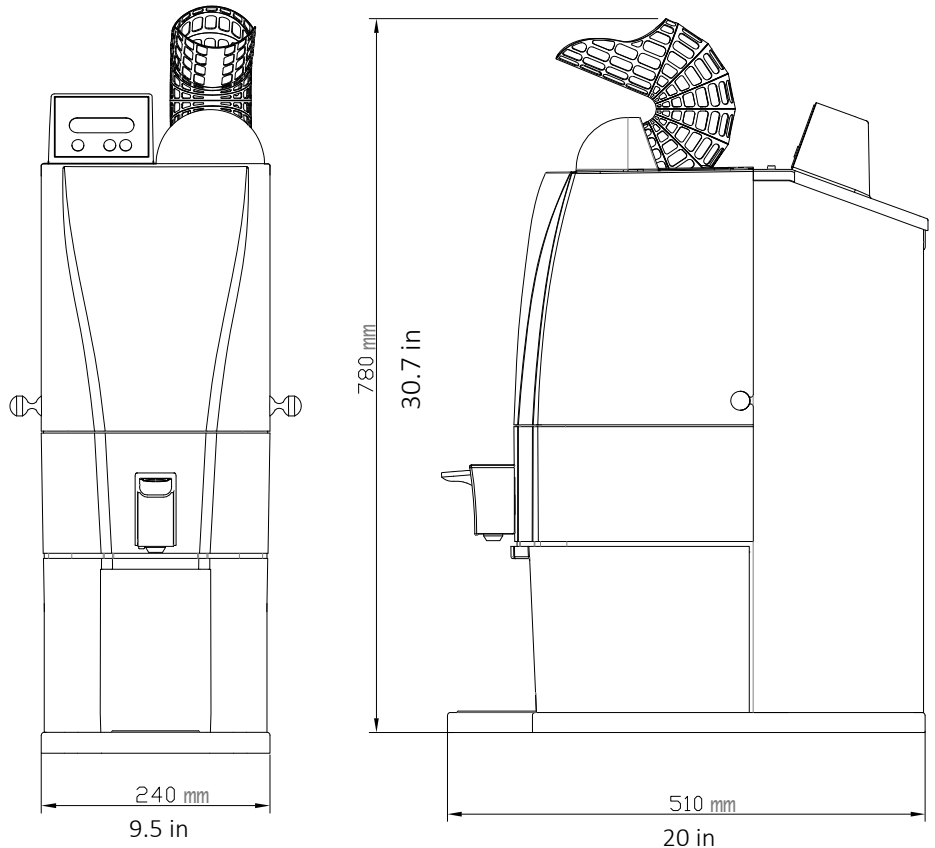

Measurements in mm/inches



FANTASTIC ECO

Off Grid, On Demand,
Truly Natural



Cut the cord for sustainability. Environmentally friendly and silent juicing – fresh, on demand, and powered by you.

CORDLESS JUICING: No electricity needed. Simply crank the wheel to start juicing. Switch between right and left-handed operation. Ideal for any location with on-demand juicing or location-flexibility needs.

SUPERIOR TASTE: Patented SCS Up&Down dynamic knife delivers precise fruit cuts, reduces peel oil, and yields sweeter-tasting juice.

MAXIMIZED HYGIENE: 304 food-grade stainless steel ensures food safety. Dishwasher-safe Double Cover and juicing parts maximize hygiene.

EFFICIENT OPERATION: One single Cross Holder secures all juicing elements and speeds up disassembly and cleaning.

UNMATCHED DURABILITY: Robust materials and design. Complete triple-sealed separation of juicing zone and gear housing for durability and longer machine life. Industry-known Citrocasa quality.

ULTIMATE VERSATILITY: Indoor, outdoor, anywhere, anytime. No plugs, no cables. Easily switch to optional Small Pressing Kit for juicing lemons and limes.

ATTRACTIVE RETURNS: Elegant eye-catching design attractively priced. Ideal for entering the world of on-demand fresh juicing.



FANTASTIC ECO

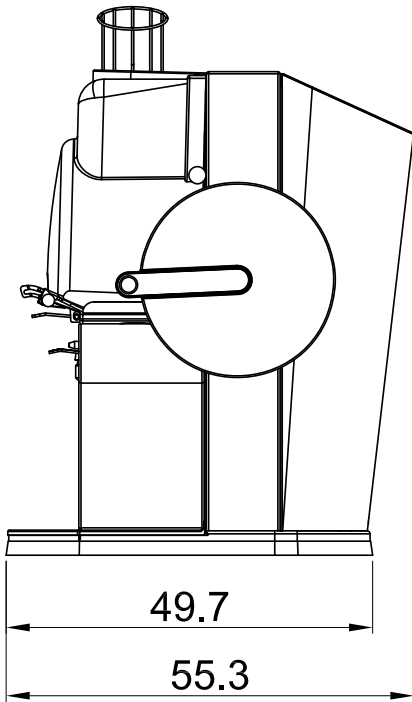
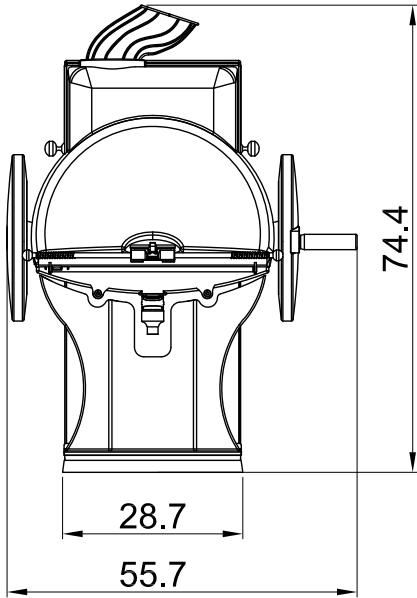

Drawing measurements in cm

| Footprint W/D:
11 / 19.5 inches

| Body W (incl. handle)/D:
22 inches

| Height:
29.5 inches

MANUAL-DRIVE CITRUS JUICER

Fruit supply tunnel

4 pieces

Fruit type

Citrus fruit

Fruit size, Standard Pressing Kit (incl.)

2.55-3.14 in

Fruit size, Small Pressing Kit (opt.)

1.96-2.55 in

Installation

Free-standing / countertop kit /
Stainless-steel cabinet

Parts and Support

(407) 790 7862

Power supply

No electricity required

Operation

Manual / Left or right-handed

Net weight

126 lb

Warranty

Limited 2-year

Certifications

NSF, TÜV Product Service, ISEGA,
ANSI and SCC accredited

www.citrusamerica.com

2-ZONE TECHNOLOGY:

Complete separation of gear housing and juicing zone with stainless-steel Double Cover for improved hygiene and cleaning efficiency.

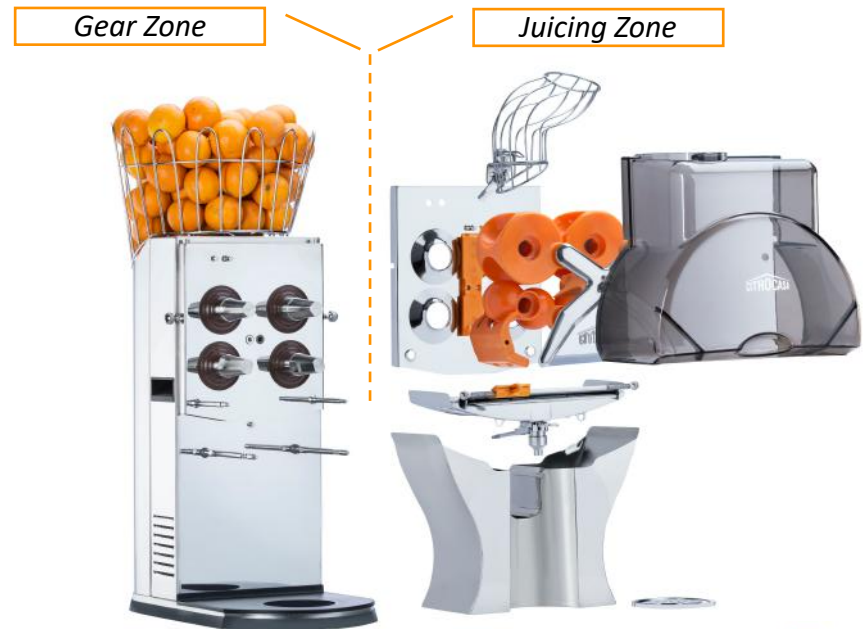

OPTIONAL ACCESSORIES:

- | Fruit Basket
- | Small Pressing Kit for lemons & limes
- | Counter-Installation Kit
- | Rolling Stainless-Steel Cabinet
- | Bottle Dispenser | Slide Tray | Display Shelf





FANTASTIC M/AS

Small Footprint
Ease of Use

MEDIUM VOLUME

30  MIN.

Pitcher in place, oranges on top, instant fresh juice. All on only 11" of counterspace.

AUTOMATIC JUICING: Simply feed fruit to start juicing. Open tap for increased labor efficiency. Ideal for staff-operated locations with limited space.

SUPERIOR TASTE: Patented SCS Up&Down dynamic knife delivers precise fruit cuts, reduces peel oil, and yields sweeter-tasting juice.

MAXIMIZED HYGIENE: 304 food-grade stainless steel ensures food safety. Dishwasher-safe Double Cover and juicing parts maximize hygiene.

EFFICIENT OPERATION: One single Cross Holder secures all juicing elements and speeds up disassembly and cleaning.

UNMATCHED DURABILITY: Robust materials and design. Complete triple-sealed separation of juicing and motor zone for durability and longer machine life.

SMART TECHNOLOGY: Multi-functional digital display with fruit counter, intelligent stop, and more.

LUCRATIVE RETURNS: Eye-catching design attractively priced. Easily switch to optional Small Pressing Kit for juicing lemons and limes.



FANTASTIC M/AS

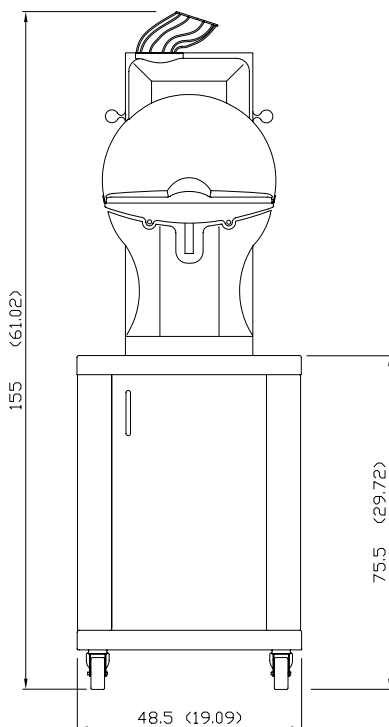
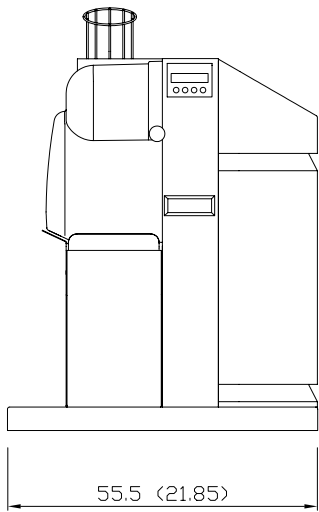
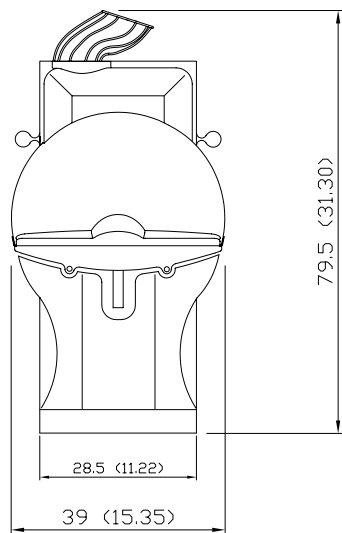

MEDIUM VOLUME CITRUS JUICER

Fruit per minute

30 pieces

Fruit supply tunnel

4 pieces

Fruit type

Citrus fruit

Fruit size, Standard Pressing Kit (*incl.*)

2.55-3.14 in

Fruit size, Small Pressing Kit (*opt.*)

1.96-2.55 in

Juicing modes

**Auto-start /
Continuous**

Installation

**Free-standing / countertop kit /
Stainless-steel cabinet**

Net weight

96 lb

Power Supply

120 V / 60 Hz

Power

200 W / 0.2 kW

Fuse / Protection

6.3 A / IPx1

Warranty

Limited 2-year

Certifications

**NSF, TÜV America, ISEGA,
ANSI and SCC accredited**

Parts and Support

(407) 790 7862

www.citrusamerica.com

2-ZONE TECHNOLOGY:

Complete separation of *motor zone* and *juicing zone* with stainless-steel Double Cover for improved hygiene and cleaning efficiency.

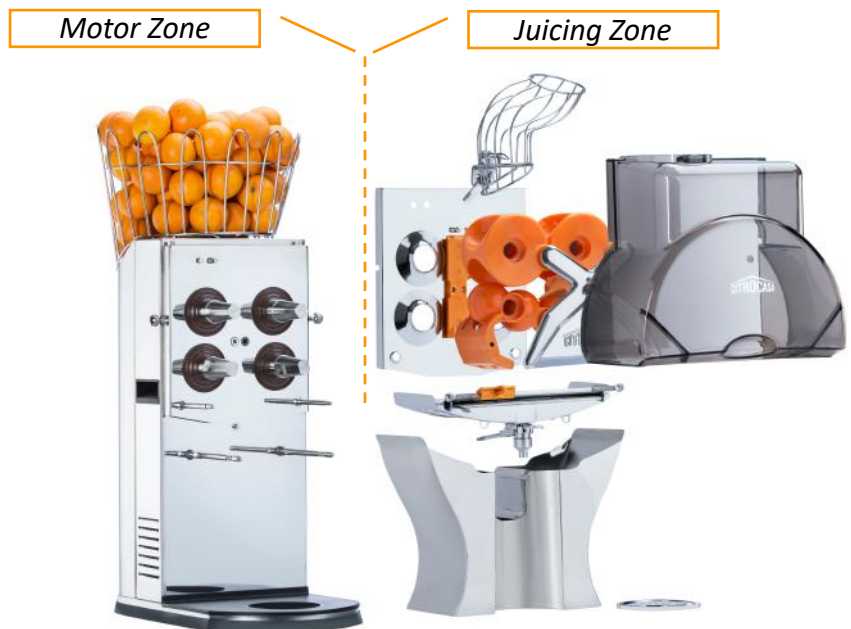

OPTIONAL ACCESSORIES:

Fruit Basket | Small Pressing Kit for lemons and limes |
Counter-Installation Kit | Rolling Stainless-Steel Cabinet |
Bottle Dispenser | Slide Tray | Display Shelf

High Powered Volume Driver

HIGH VOLUME

40  MIN.

Our robust juicer for staff-operation, pre-portioning, and commissary strategies: Ideal for freshly squeezed into bottles or cups.

- POWERFUL RETURNS:** Staff-operation at 40 fruit/minute. Convenient juice tank for high-volume juicing and pre-bottling.
- SUPERIOR TASTE:** Patented SCS Up&Down dynamic knife delivers precise fruit cuts, reduces peel oil, and yields sweeter-tasting juice.
- MAXIMIZED HYGIENE:** 304 food-grade stainless steel ensures food safety. Dishwasher-safe Double Cover and juicing parts maximize hygiene.
- EFFICIENT OPERATION:** One single Cross Holder secures all juicing elements and speeds up disassembly and cleaning.
- UNMATCHED DURABILITY:** Robust materials and design. Complete triple-sealed separation of juicing and motor zone for durability and longer machine life.
- SMART TECHNOLOGY:** Multi-functional digital display with fruit counter, intelligent stop, and more.
- LUCRATIVE RETURNS:** Stainless-steel rolling cabinet available for longer uninterrupted juicing and added mobility. Optional pressing kits so you can offer greater juice variety: lemon, lime, tangerine, orange, and grapefruit all from one single juicer.



8000XB

Fruit per minute

40 pieces

Fruit supply basket

46 lb

Fruit type

Citrus fruit

Fruit size, Standard Pressing Kit (incl.)

2.55-3.14 in

Fruit size, Small Pressing Kit (optional)

1.96-2.55 in

Fruit size, Large Pressing Kit (optional)

3.15-3.50 in

Juicing modes

Continuous / Programmed / Manual
release tap and juice tank

Installation

Free-standing / Countertop kit /

Stainless-steel cabinet (recommended)

Net weight: Juicer / Juicer on Cabinet

159 lb / 246 lb

Power Supply

120 V / 60 Hz

Power

200 W / 0.2 kW

Fuse / Protection

6.3 A / IPx1

Warranty

Limited 2-year

Certifications

NSF, TÜV America, ISEGA,

ANSI and SCC accredited

Parts and Support

(407) 790 7862

www.citrusamerica.com

www.juicertraining.com

HIGH VOLUME CITRUS JUICER

40  MIN.

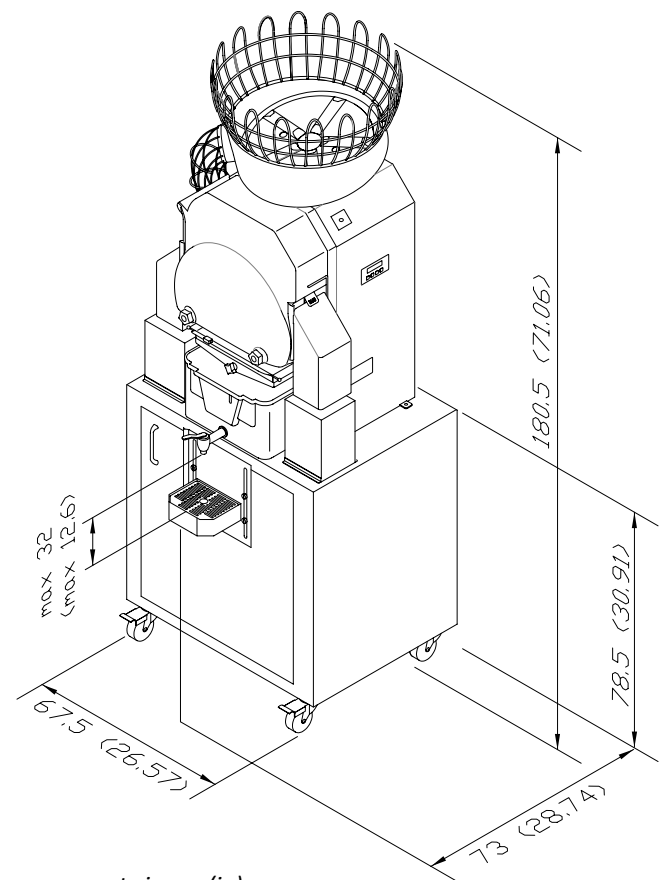
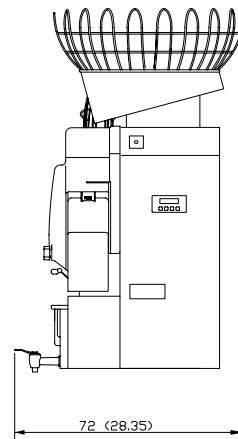
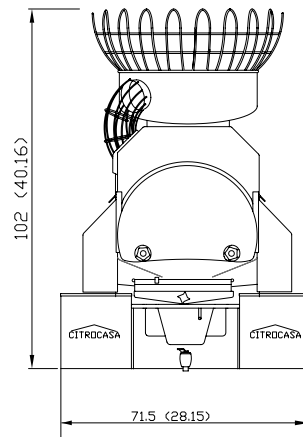

Measurements in cm (in)



2-ZONE-TECHNOLOGY:

Complete separation of *motor zone* and *juicing zone* with stainless-steel Double Cover for improved hygiene and cleaning efficiency.

OPTIONAL ACCESSORIES:

- | Small Pressing Kit for small citrus: lemons, limes, tangerines
- | Large Pressing Kit for large citrus: large oranges, grapefruit
- | Counter-Installation Kit | Rolling Stainless-Steel Cabinet
- | Bottle Dispenser | Slide Tray | Display Shelf



Small Pressing Kit for lemons/limes



Large Pressing Kit for grapefruit



FANTASTIC F/SB-ATS

Advanced Performance Exceptional Appeal

MEDIUM TO HIGH VOLUME

30  MIN.

Wow your customers with the most technology on the smallest footprint.

ON-DEMAND JUICING: Aesthetically appealing for storefront self-service and highly efficient for staff-operation. The most you can get on only 11" of counterspace.

SUPERIOR TASTE: Patented SCS Up&Down dynamic knife delivers precise fruit cuts, reduces peel oil, and yields sweeter-tasting juice. ATS self-clearing sieve automatically removes seeds and excessive pulp.

MAXIMIZED HYGIENE: 304 food-grade stainless steel ensures food safety. Dishwasher-safe Double Cover and juicing parts maximize hygiene.

EFFICIENT OPERATION: One single Cross Holder secures all juicing elements and speeds up disassembly and cleaning.

UNMATCHED DURABILITY: Robust materials and design. Complete triple-sealed separation of juicing and motor zone for durability and longer machine life. Sturdy stainless-steel tap for high-frequency use.

SMART TECHNOLOGY: Multi-functional digital display with fruit counter, intelligent stop, and more.

LUCRATIVE RETURNS: Exceptional design for a unique customer experience. Easily switch to optional Small Pressing Kit for juicing lemons and limes.



11"

FANTASTIC F/SB-ATS

MEDIUM TO HIGH VOLUME CITRUS JUICER

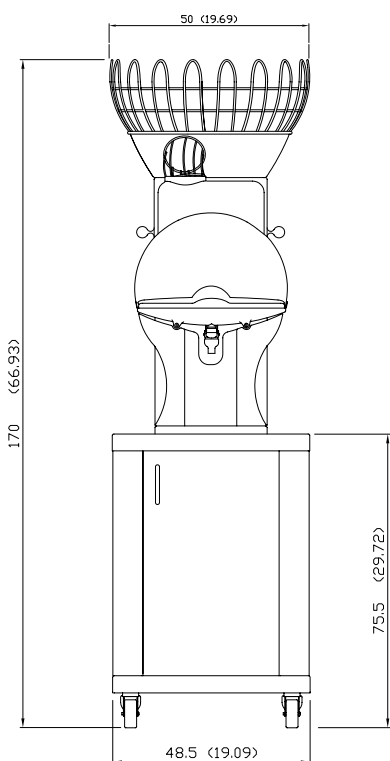
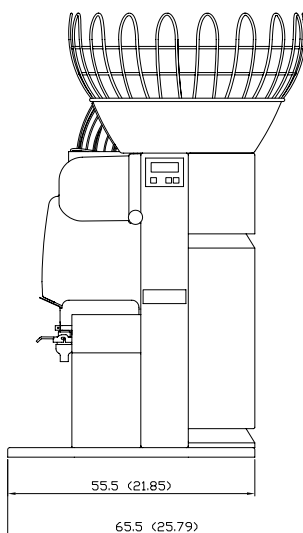
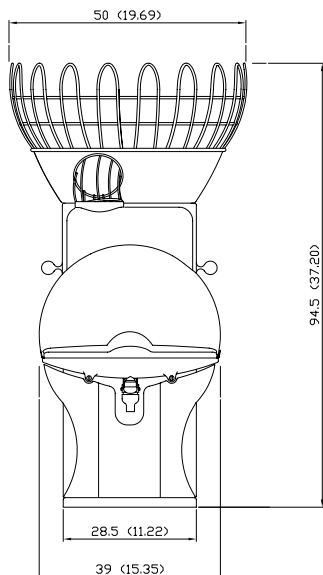

Measurements in cm (in)

Fruit per minute

30 pieces

Fruit supply basket

37 lb

Fruit type

Citrus fruit

Fruit size, Standard Pressing Kit (incl.)

2.55-3.14 in

Fruit size, Small Pressing Kit (opt.)

1.96-2.55 in

Juicing modes

**Self-service tap /
Continuous**

Installation

**Free-standing / countertop kit /
Stainless-steel cabinet**

Net weight

126 lb

Power Supply

120 V / 60 Hz

Power

200 W / 0.2 kW

Fuse / Protection

6.3 A / IPx1

Warranty

Limited 2-year

Certifications

**NSF, TÜV America, ISEGA,
ANSI and SCC accredited**

Parts and Support

(407) 790 7862

www.citrusamerica.com

2-ZONE TECHNOLOGY:

Complete separation of *motor zone* and *juicing zone* with stainless-steel Double Cover for improved hygiene and cleaning efficiency.

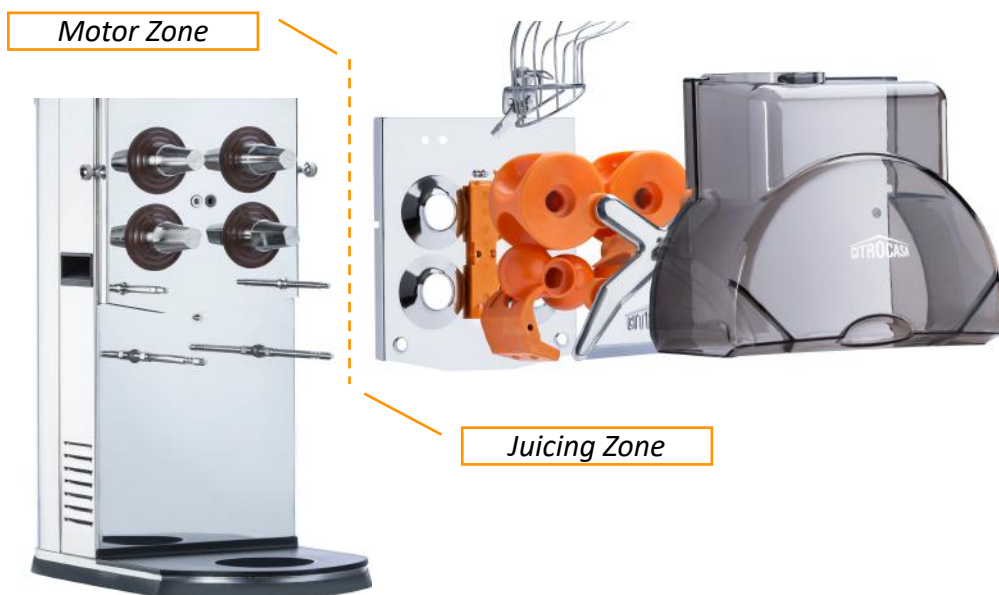

OPTIONAL ACCESSORIES:

Small Pressing Kit for lemons and limes |
Counter-Installation Kit | Rolling Stainless-Steel Cabinet |
Bottle Dispenser | Slide Tray | Display Shelf

Industry-Leading Powerhouse

HIGHEST VOLUME

40  MIN.

The industry-leading juicer for high-volume self-service and staff-operation: The most advanced and flexible model for your juicing needs.

POWERFUL RETURNS: Self-service and staff-operation at 40 fruit/minute. The most advanced technology for highly frequented locations.

SUPERIOR TASTE: Patented SCS Up & Down dynamic knife delivers precise fruit cuts, reduces peel oil and yields sweeter-tasting juice. ATS self-clearing sieve automatically removes seeds and excessive pulp.

MAXIMIZED HYGIENE: 304 food-grade stainless steel ensures food safety. Dishwasher-safe Double Cover and juicing parts maximize hygiene.

EFFICIENT OPERATION: One single Cross Holder secures all juicing elements and speeds up disassembly and cleaning.

UNMATCHED DURABILITY: Robust materials and design. Complete triple-sealed separation of juicing and motor zone for durability and longer machine life. Sturdy stainless-steel tap for high-frequency use.

SMART TECHNOLOGY: Multi-functional digital display with fruit counter, intelligent stop, and more.

LUCRATIVE RETURNS: Stainless-steel rolling cabinet for longer uninterrupted juicing and added mobility. Optional pressing kits so you can offer greater juice variety: lemon, lime, tangerine, orange, and grapefruit all from one single juicer.



8000SB-ATS

Fruit per minute

40 pieces

Fruit supply basket

46 lb

Fruit type

Citrus fruit

Fruit size, Standard Pressing Kit (incl.)

2.55-3.14 in

Fruit size, Small Pressing Kit (optional)

1.96-2.55 in

Fruit size, Large Pressing Kit (optional)

3.15-3.50 in

Juicing modes

Continuous / Self-service tap /

Automatic seed and pulp removal

Installation

Stainless-steel cabinet mounted

(juicer must be mounted)

Net weight: Juicer / Juicer on Cabinet

173 lb / 260 lb

Power Supply

120 V / 60 Hz

Power

200 W / 0.2 kW

Fuse / Protection

6.3 A / IPx1

Warranty

Limited 2-year

Certifications

NSF, TÜV America, ISEGA,

ANSI and SCC accredited

Parts and Support

(407) 790 7862

www.citrusamerica.com

www.juicertraining.com

HIGH VOLUME CITRUS JUICER

40  MIN.

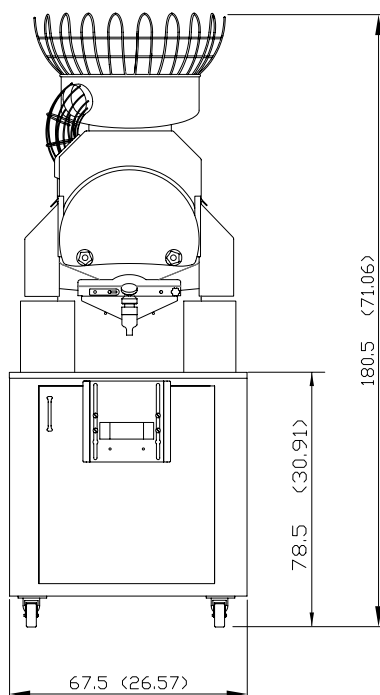

Measurements in cm (in)

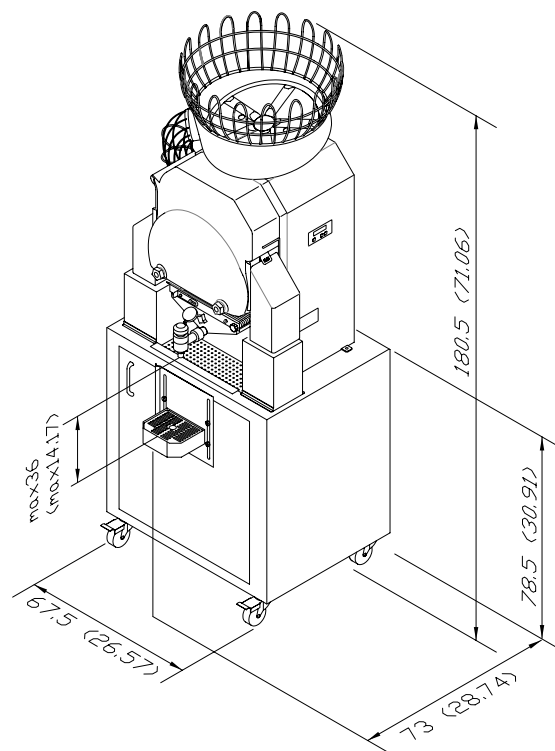

2-ZONE-TECHNOLOGY:

Complete separation of motor zone and juicing zone with stainless-steel Double Cover for improved hygiene and cleaning efficiency.

ATS (Automatic Transport System):

Automatic removal of seeds and excessive pulp

OPTIONAL ACCESSORIES:

- | Small Pressing Kit for small citrus: lemons, limes, tangerines
- | Large Pressing Kit for large citrus: large oranges, grapefruit
- | Counter-Installation Kit | Rolling Stainless-Steel Cabinet
- | Bottle Dispenser | Slide Tray | Display Shelf



Small Pressing Kit for lemons/limes



Large Pressing Kit for grapefruit